













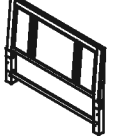
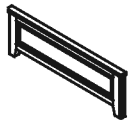

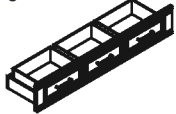

**INTERCON**  
FURNITURE FOR LIFE

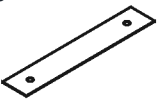
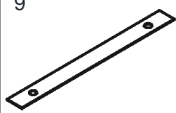
# ASSEMBLY INSTRUCTION

DESCRIPTION: KING PANEL BED

ITEM NO: CR-BR-9765K-WSL-HB / CR-BR-9765K-WSL-FB  
CR-BR-9765QK-WSL-RS / CR-BR-9765S-WSL-RS

Thank you for purchasing this quality product. Be sure to check all packing material carefully for small parts which may have come loose inside the carton during shipment. Identify and count all parts and compare with the parts list below. Please keep all hardware out of reach of small children.

1  HEADBOARD 1 PC	2  FOOTBOARD 1 PC	3  SLAT 5 Pcs	4  SUPPORT LEGS 10 Pcs	5  Q/K SIDE RAILS 2 Pcs	6  Q/K STORAGE RAILS 2 Pcs	7  SUPPORT LEGS 10 Pcs	8  DECKING PANEL 4 Pcs
9  DECKING PANEL 2 Pcs							
A  BLOT 5/16" x 3" 8 Pcs	B  SPRING WASHER 5/16" 8 Pcs	C  FLAT WASHER 5/16" 8 Pcs	D  HALF MOON WASHER 29 x 15 x 7.5mm 8 Pcs	E  HEX NUT Ø5/16" x 12mm 8 PC	F  WRENCH 1 PC	G  WOOD SCREW #8 x 1" 10 Pcs	 SCREWDRIVER NOT PROVIDED

## STEP 1

### KING BED WITH Q/K STANDARD RAILS

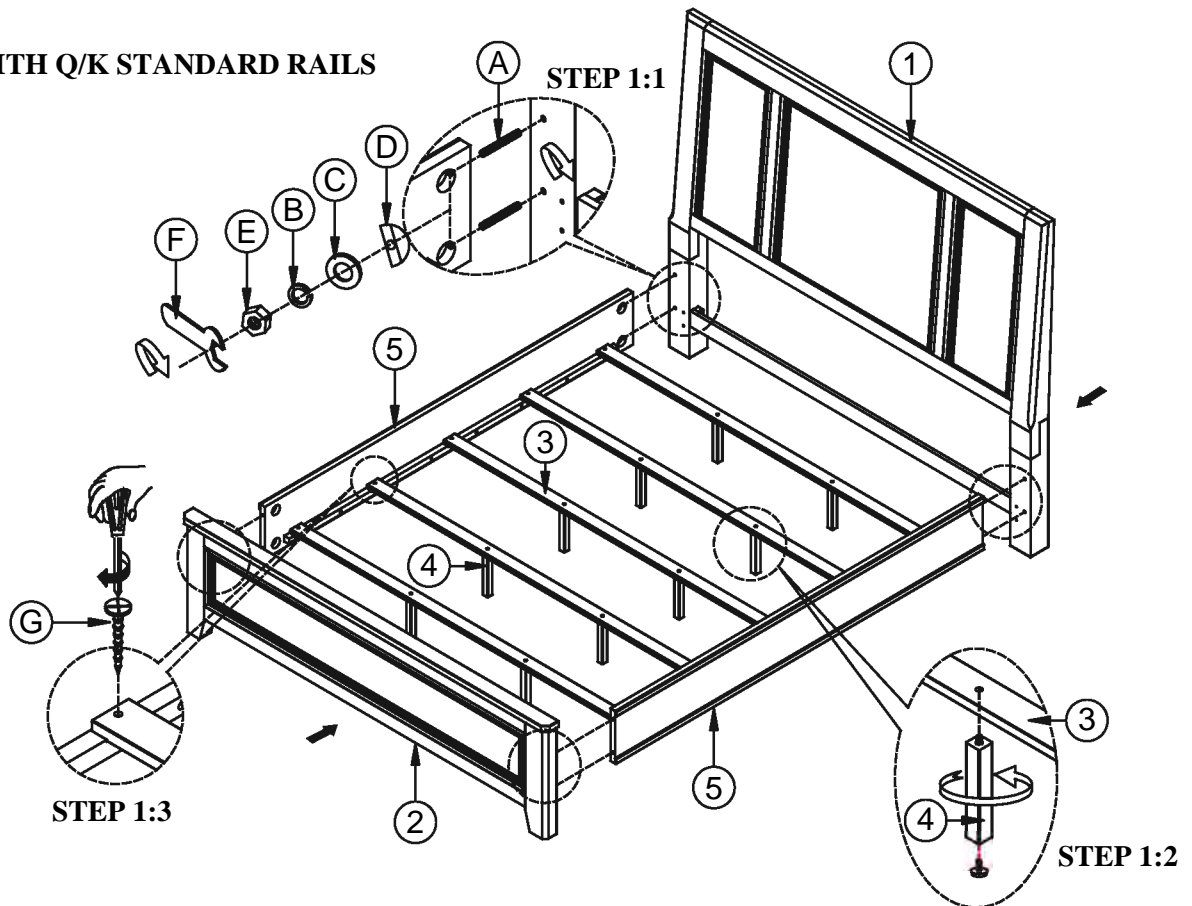

#### ASSEMBLY TIPS:

1. Remove hardware from box and sort by size.
2. Please check to see that all hardware and parts are present prior start of assembly.
3. Please follow attached instructions in the same sequence as numbered to assure fast and easy assembly.

#### ⚠ WARNING!

1. Don't attempt to repair or modify parts that are broken or defective. Please contact the store immediately.
2. This product is for home use only and not intended for commercial establishments.



**INTERCON**  
FURNITURE FOR LIFE

# ASSEMBLY INSTRUCTION

DESCRIPTION: KING PANEL BED

ITEM NO: CR-BR-9765K-WSL-HB / CR-BR-9765K-WSL-FB

ITEM NO: CR-BR-9765QK-WSL-RS / CR-BR-9765S-WSL-RS

Thank you for purchasing this quality product. Be sure to check all packing material carefully for small parts which may have come loose inside the carton during shipment. Identify and count all parts and compare with the parts list below. Please keep all hardware out of reach of small children.

## STEP 1

### KING BED WITH Q/K STORAGE RAILS

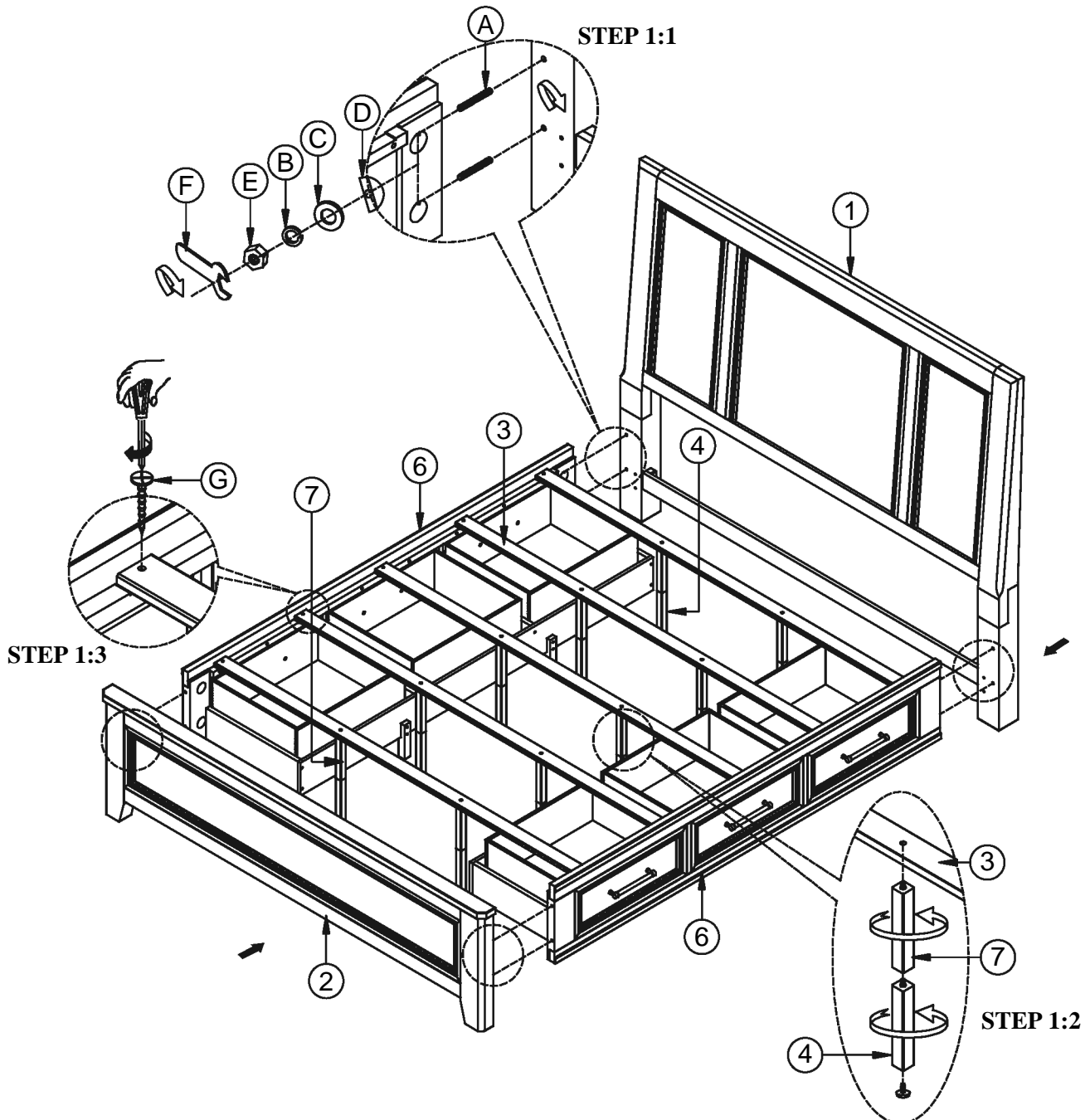

#### ASSEMBLY TIPS:

1. Remove hardware from box and sort by size.
2. Please check to see that all hardware and parts are present prior start of assembly.
3. Please follow attached instructions in the same sequence as numbered to assure fast and easy assembly.

#### **⚠ WARNING!**

1. Don't attempt to repair or modify parts that are broken or defective. Please contact the store immediately.
2. This product is for home use only and not intended for commercial establishments.



**INTERCON**  
FURNITURE FOR LIFE

# ASSEMBLY INSTRUCTION

DESCRIPTION: KING PANEL BED

ITEM NO: CR-BR-9765K-WSL-HB / CR-BR-9765K-WSL-FB  
CR-BR-9765QK-WSL-RS / CR-BR-9765S-WSL-RS

Thank you for purchasing this quality product. Be sure to check all packing material carefully for small parts which may have come loose inside the carton during shipment. Identify and count all parts and compare with the parts list below. Please keep all hardware out of reach of small children.

## STEP 2

### KING BED WITH Q/K STORAGE RAILS

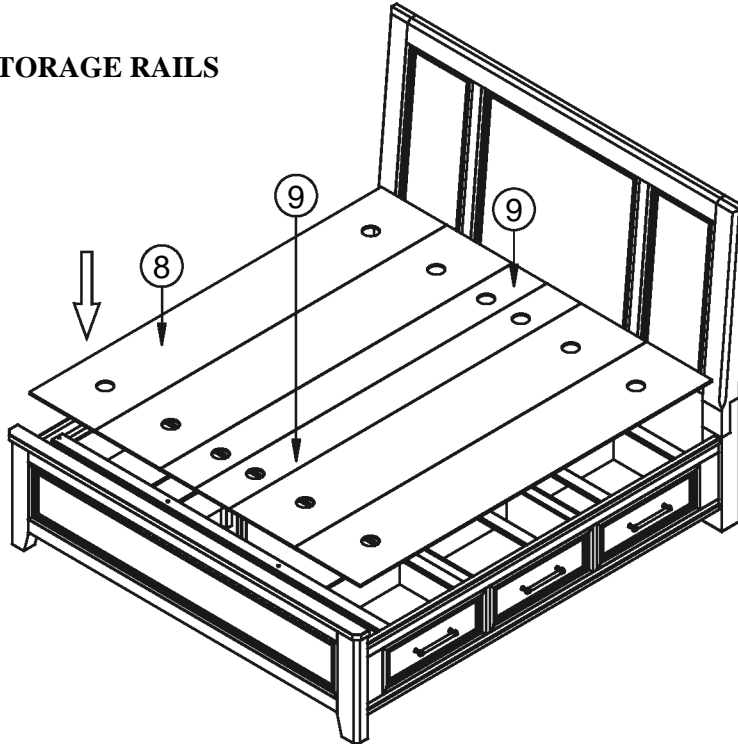

### KING BED WITH Q/K STANDARD RAILS

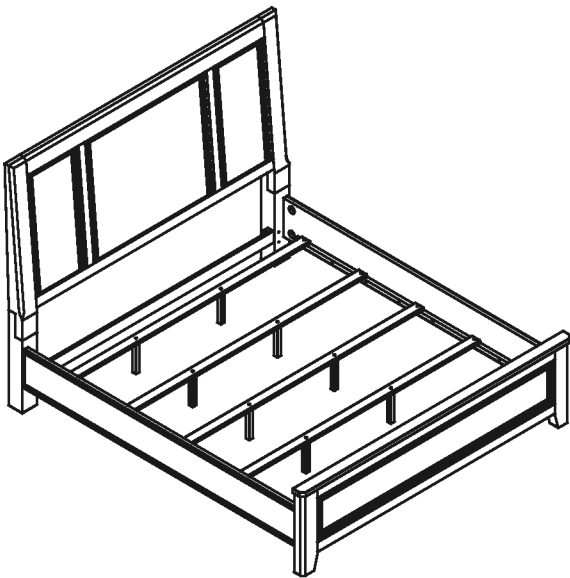

### COMPLETE ASSEMBLY

### KING BED WITH Q/K STORAGE RAILS

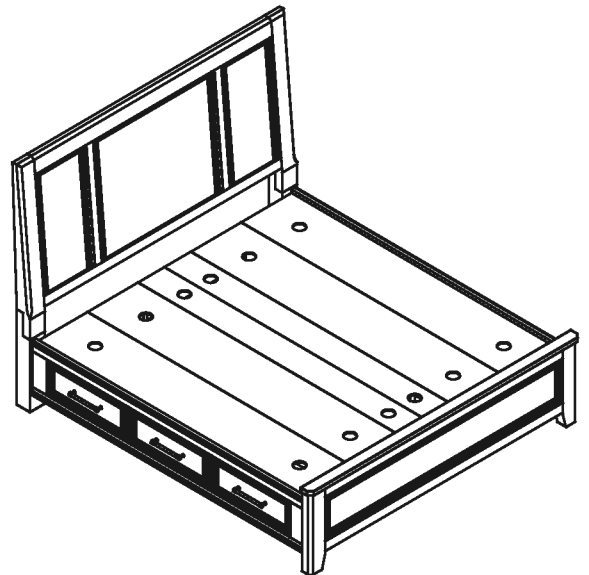

### COMPLETE ASSEMBLY

#### ASSEMBLY TIPS:

1. Remove hardware from box and sort by size.
2. Please check to see that all hardware and parts are present prior start of assembly.
3. Please follow attached instructions in the same sequence as numbered to assure fast and easy assembly.

#### WARNING!

1. Don't attempt to repair or modify parts that are broken or defective. Please contact the store immediately.
2. This product is for home use only and not intended for commercial establishments.